

MED64 Channel Divider (16ch x 4)

<MED-B02>



*Signals are acquired simultaneously from 4 slices and cultures.

*Ideal solution for high throughput screening.

*Easily connected to your current MED64 system.

*Conductor software can be used to record from 16 channels per probe. Four stimulators can also be used (e.g. 1 stimulator per probe).

System diagram

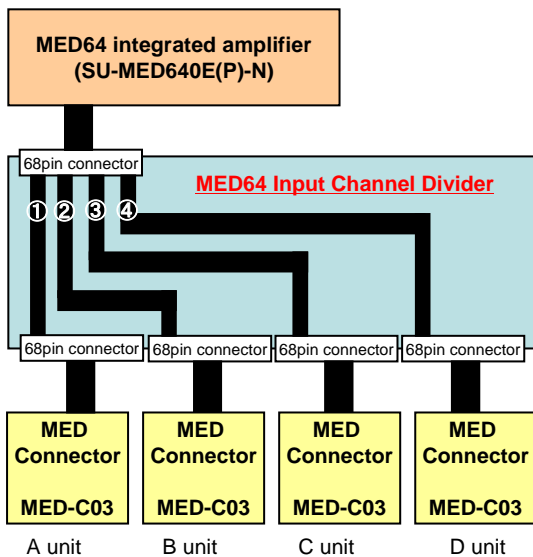

Electrodes to record and stimulate (unit A-D)

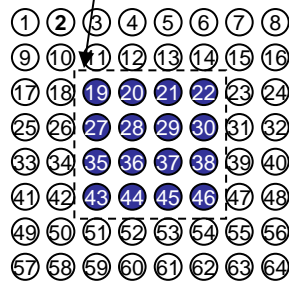

View of recorded data on the screen

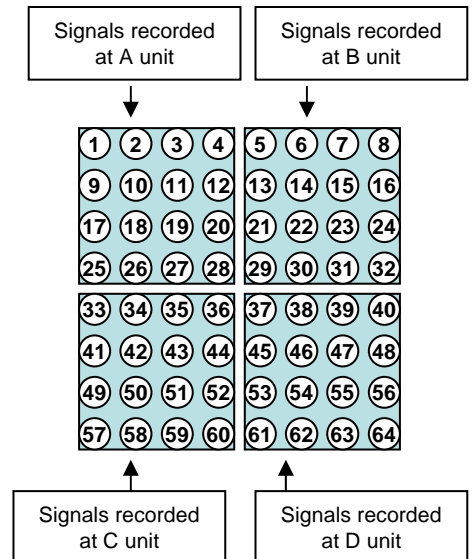

Specification



Input: 4 lines (16ch each)
Output: 1 line (64ch)
Input Terminal: 68 pin type, 20 pin type / each line
Material: Aluminum and Steel

Notice:

- *This product can not be used with the "Performer" software.
- *Signals are acquired through the central 16 electrodes out of 64 on each of the 4 probes. (Slice or culture on the 4 probes are not recorded independently.)
- *Stimulation can be applied through up to four electrodes over 4 probes.

* The system may not apply to all types of experiment in this field. Ask us for your specific requirements.