



Europäisches Patentamt
European Patent Office
Office européen des brevets



(11) **EP 1 040 345 B1**

(12) **EUROPEAN PATENT SPECIFICATION**

(45) Date of publication and mention
of the grant of the patent:
22.03.2006 Bulletin 2006/12

(51) Int Cl.:
G01N 27/403^(2006.01) G01N 33/487^(2006.01)
C12M 1/34^(2006.01)

(21) Application number: **98966077.4**

(86) International application number:
PCT/US1998/027489

(22) Date of filing: **22.12.1998**

(87) International publication number:
WO 1999/034202 (08.07.1999 Gazette 1999/27)

(54) **CELL POTENTIAL MEASURING ELECTRODE AND MEASURING APPARATUS USING THE SAME**
ELEKTRODE UND VORRICHTUNG ZUR MESSUNG VON ZELLPOTENTIALEN
ELECTRODE DE MESURE DE POTENTIEL DE CELLULE ET APPAREIL DE MESURE UTILISANT
CETTE ELECTRODE

(84) Designated Contracting States:
AT BE CH CY DE DK ES FI FR GB GR IE IT LI LU
MC NL PT SE

(74) Representative: **Vossius & Partner**
Postfach 86 07 67
81634 München (DE)

(30) Priority: **25.12.1997 JP 35860197**

(56) References cited:
EP-A- 0 689 051 EP-A- 0 823 483
WO-A-98/54294 DE-A- 19 529 371
US-A- 5 187 096

(43) Date of publication of application:
04.10.2000 Bulletin 2000/40

(73) Proprietor: **MATSUSHITA ELECTRIC INDUSTRIAL**
CO., LTD.
Kadoma-shi, Osaka-fu 571-8501 (JP)

- **HINKERS H ET AL: "AN AMPEROMETRIC MICROSENSOR ARRAY WITH 1024 INDIVIDUALLY ADDRESSABLE ELEMENTS FOR TWO-DIMENSIONAL CONCENTRATION MAPPING" SENSORS AND ACTUATORS B, vol. B24, no. 1/03, PART 01, 1 March 1995, pages 300-303, XP000521341 lausanne, ch**
- **KORDAS N ET AL: "A CMOS-COMPATIBLE MONOLITHIC CONDUCTIVITY SENSOR WITH INTEGRATED ELECTRODES" SENSORS AND ACTUATORS A, vol. A43, no. 1/03, 1 May 1994, pages 31-37, XP000454083 lausanne, ch**
- **MOHR A ET AL: "PERFORMANCE OF A THIN FILM MICROELECTRODE ARRAY FOR MONITORING ELECTROGENIC CELLS IN VITRO" SENSORS AND ACTUATORS B, vol. 34, no. 1/03, August 1996, pages 265-269, XP000641664 lausanne, ch**

(72) Inventors:

- **SUGIHARA, Hirokazu**
Katano-shi,
Osaka 576-0054 (JP)
- **OKA, Hiroaki,**
Hirakata Garden Hills 913
Hirakata-shi,
Osaka 573-1194 (JP)
- **SHIMONO, Ken**
Irvine, CA 92612 (US)
- **OGAWA, Ryuta**
Moriguchi-shi,
Osaka 570-0031 (JP)
- **TAKETANI, Makoto**
Irvine, CA 92614 (US)

Note: Within nine months from the publication of the mention of the grant of the European patent, any person may give notice to the European Patent Office of opposition to the European patent granted. Notice of opposition shall be filed in a written reasoned statement. It shall not be deemed to have been filed until the opposition fee has been paid. (Art. 99(1) European Patent Convention).

EP 1 040 345 B1

Description

Field of the Invention

[0001] This invention relates to a low impedance cell potential measuring electrode assembly typically having a number of microelectrodes on an insulating substrate and having a wall enclosing the region including the microelectrodes. The device is capable of measuring electrophysiological activities of a monitored sample using the microelectrodes while cultivating those cells or tissues in the region of the microelectrodes. The invention utilizes independent reference electrodes to lower the impedance of the overall system and to therefore lower the noise often inherent in the measured data. Optimally the microelectrodes are enclosed by a physical wall used for controlling the atmosphere around the monitored sample.

Background of the Invention

[0002] Cell potential measuring apparatus have been developed to measure the activity or electrical potential generated by activity of nerve cells, other cells, or tissues (for example, Japanese Kokai 8-62209) without inserting glass electrodes or the like into the cells.

[0003] Measurement of cell potential by inserting a glass electrode or the like into the cell may damage that cell. Long term measurement of cell potential is quite difficult. It is further difficult to measure plural positions simultaneously; there is a limit to the number of electrodes one can place in a measurement electrode array and it is similarly difficult to adequately determine the position of the sample over measurement electrodes. In contrast, use of a cell potential measuring electrode having plural microelectrodes on a substrate (having a wall for enclosing a region including the microelectrodes), allows cultivation of the cells within the region enclosed by the wall and the simultaneous measurement of the potential of plural positions without damaging those cells.

[0004] These cell potential measuring devices measure cell potential against a reference. One such way is discussed with regard to Kokai 8-62209 (family member of EP-A-0 689 051). When 64 microelectrodes are arranged in eight columns and eight rows, theoretically, by using one microelectrode as the reference potential (that is, as a common reference electrode connected to the potential of the culture medium) the cell potential of the other 63 positions can be measured simultaneously by using the remaining 63 microelectrodes.

[0005] However, when measuring very low level or micro-potentials such as cell potentials, noise is a problem. Noise level varies significantly depending on the selection of the type and location of the reference electrode. As mentioned above, when using one microelectrode as a reference electrode, simultaneous measurement of potential at 63 positions by using the remaining 63 microelectrodes is impossible because of the high noise level.

When the reference electrodes and measuring electrodes correspond one-by-one to each other, the potential may be measured at a very low noise level state; But if 64 microelectrodes are used, for example, corresponding to 32 reference electrodes and 32 measuring electrodes, only 32 positions can be measured simultaneously.

[0006] In theory, though, one must limit the number of reference electrodes in order to simultaneously measure the potential at as many positions as possible.

[0007] As shown in Fig. 14 of Kokai 8-62209, eight microelectrodes in one row are used as reference electrodes and seven measuring electrodes each are correlated to each of the reference electrodes, so that the potential can be measured simultaneously at $7 \times 8 = 56$ positions. If 56 microelectrodes are used as measuring electrodes, i.e., by using eight microelectrodes in one row as reference electrodes, the loss of measuring sites is about 12% as compared with the case of using all 64 or 63 pieces as measuring electrodes. However, even when seven measuring electrodes are used with one reference electrode, the noise is still quite large. It is quite difficult to detect a small change in cell potential from the noise.

[0008] Moreover, as shown in Fig. 14 of Kokai 8-62209, when placing a segment S of cell or tissue on the plural microelectrodes, the segment S should not be placed on the row of microelectrodes used as reference electrodes. Such a placement requires skill and is difficult because the segment S must be held by tweezers and moved while observing the segment through a microscope. It is extremely difficult to place the segment S so that the eight microelectrodes in one row are completely exposed, while the remaining 56 microelectrodes be completely covered with the segment. If the segment S is placed to completely expose the eight microelectrodes in one row, usually some of the remaining 56 are exposed, and hence the number of positions for simultaneous measurement is decreased. Sensors and Actuators B, vol. B24, no 1/03, part 1, March 1995, p 300-303, discloses an array of working electrodes with corresponding reference electrodes positioned next to the working electrodes.

SUMMARY OF THE INVENTION

[0009] The invention is intended to solve such problems. This invention provides a cell potential measuring electrode less susceptible to noise and is yet capable of simultaneously measuring the potential at many positions by effectively utilizing all of the available microelectrodes if the positioning is not very precise when placing the segment of cell or tissue to be measured.

[0010] The cell potential measuring electrode of the invention preferably includes plural microelectrodes on an insulating substrate, a conductive pattern for connecting the microelectrodes to some region out of the microelectrode area, electric contacts connected to the end of

the conductive pattern, an insulating film covering the surface of the conductive pattern, and a wall enclosing the region including the microelectrodes on the surface of the insulating film. The inventive reference electrodes have a comparatively lower impedance than the impedance of the measuring microelectrodes. They are respectively placed at plural positions in the region enclosed by the wall and often at a specific distance from the microelectrodes. The electrical contacts are further usually connected between the conductive pattern for wiring of each reference electrode and the end of the conductive pattern. The surface of the conductive pattern for wiring of the reference electrodes is typically covered with an insulating film.

[0011] According to this invention, since exclusive reference electrodes are provided at plural positions distant from the region of plural measurement microelectrodes, it is easy to place the segment of cell sample to cover all microelectrodes while not contacting with the reference electrodes. The reference electrode would typically have, for example, a larger area than a measurement microelectrode and hence is smaller in impedance. Therefore the noise level is small even if connected commonly to plural reference potentials for measuring positions. Therefore, common reference electrodes can be used with multiple measurement microelectrodes. Moreover, since each one of the plural reference electrodes is responsible for multiple measurement microelectrodes, the cell potentials may be easily measured simultaneously using all of microelectrodes.

[0012] Preferably, the plural reference electrodes are placed at nearly equal distances from the plural microelectrode region and at intervals of nearly equal angle. By "intervals of nearly equal angle", we mean that when the plural microelectrode region is viewed from above, the plural reference electrodes extend away from that region in equi-angular rays. More preferably, the plural microelectrodes are placed in a rectangular matrix, and four of the reference electrodes are provided on an extension of diagonals of the region holding that rectangular matrix. In such a symmetrical placement, the noise level to each microelectrode is averaged.

[0013] As a specific example, the microelectrodes are situated in a matrix arrangement in a rectangle having sides of, e.g., 0.8 to 2.2 mm (in the case of 300 μm microelectrode pitch) or 0.8 to 3.3 mm (in the case of 450 μm microelectrode pitch). Four reference electrodes are situated at four corners of a rectangle of 5 to 15 mm on one side. More preferably, 64 microelectrodes are disposed in eight rows and eight columns at central pitches of about 100 to 450 μm , preferably 100 to 300 μm .

[0014] In order to set the impedance of the reference electrodes to be sufficiently smaller than the impedance of the microelectrodes, the area of the reference electrodes is preferably 4 to 25 times (particularly preferably 16 times) the area of the microelectrodes. As a specific example, the area of each of the microelectrodes is preferably between about 4×10^2 and $4 \times 10^4 \mu\text{m}^2$ and the

area of each of the reference electrodes is preferably between about 64×10^2 and $64 \times 10^4 \mu\text{m}^2$.

[0015] Preferably the microelectrodes and the reference electrodes are formed from the same material to both simplify the manufacturing process and obtain a cost benefit. Preferably, the microelectrodes and the reference electrodes are formed of layers of nickel plating, gold plating, and platinum black on an indium-tin oxide (ITO) film. After platinization, the impedance of the reference electrodes is preferably between 2 and 3 kilohms.

[0016] The insulating substrate (for example, a glass substrate) may be nearly square. Plural electric contacts may be connected to the end of the conductive pattern and preferably are placed on the four sides of the insulating substrate. As a result, layout of wiring patterns of multiple microelectrodes and reference electrodes is easy. Because the pitches of electric contacts may be made to be relatively large, electric connection through the electric contacts with external units is also easy.

[0017] The microelectrode region is usually very small. When observing the sample through a microscope, it is hard to distinguish position and both vertical and lateral directions. It is desirable to place indexing micro-marks near the microelectrode region to allow visual recognition through the microscope variously of direction, axes, and position.

[0018] The most preferred cell potential measuring apparatus of this invention is made up of a cell placement device having cell potential measuring electrodes, contact sites for contacting with an electric contact, and an electrode holder for fixing the insulating substrate by sandwiching from above and beneath. In a variation of the invention, a signal processor may be placed near the microelectrode matrix or region. The cell potential measuring electrodes may be connected electrically to the cell placement assembly device to allow processing of the voltage signals generated by the sample and measured between each such microelectrode and the reference electrodes. The cell potential measuring assembly usually includes a region enclosed by a wall for cultivating sample cells or tissues. It also preferably includes an optical device for magnifying and observing optically the cells or tissues cultivated in the region enclosed by the wall. This cell potential measuring apparatus preferably further comprises an image memory device for storing the magnified image obtained by the optical device.

BRIEF DESCRIPTION OF THE DRAWINGS

[0019]

Fig. 1 is a block diagram showing an entire structure of a cell potential measuring apparatus according to the invention.

Fig. 2 is an exploded view of a cell placement device including the cell potential measuring electrode of the invention.

Fig. 3 is a partial plan view showing an example of microelectrodes in the central part of the cell potential measuring apparatus and a conductive pattern for its wiring.

Fig. 4 is a plan view showing an entire structure of a cell potential measuring electrode.

Fig. 5 is a schematic diagram of a section of a cell potential measuring electrode.

Fig. 6 is a plan view and a side sectional view showing a state of fixing the cell potential measuring electrode by sandwiching with upper and lower holders.

Fig. 7 is a perspective view of the cell potential measuring electrode and upper and lower holders in Fig. 6.

Fig. 8 is a side view of contact metal fittings provided in the upper holder.

Fig. 9 is a waveform diagram showing noise level in the case of 50-micron square size of reference electrodes provided in the cell potential measuring electrode.

Fig. 10 is a waveform diagram showing noise level in the case of 200-micron square size of reference electrodes provided in the cell potential measuring electrode.

Fig. 11 is a diagram showing the central seven measurement sites within the measuring region of the cell potential measuring electrode.

Fig. 12 is a block diagram showing an example of measuring method of cell potential by using a conventional cell potential measuring electrode.

DESCRIPTION OF THE INVENTION

[0020] Fig. 1 shows a typical example of an entire cell potential measuring apparatus using a cell potential measuring electrode and reference electrode made according to the invention. This cell potential measuring apparatus comprises an integrated cell placement device 1 containing the cell potential measuring electrode of the invention, an optical observation device 20 including an inverted microscope 21 for optically measuring the sample or cells placed in the cell placement device 1, a computer 30 for giving a stimulus signal to the cells and for processing the output signal from the cells, and a cell culture system 40 for maintaining a culture atmosphere about the sample.

[0021] In addition to the inverted microscope 21 upon which the cell placement device 1 is set, the optical observation device 20 may also comprise an SIT camera 22 for the microscope 21, a high definition display 23,

and an image memory device 24. The high definition display 23 may be also used as the display for the computer 30.

[0022] The computer 30 usually is a personal computer (PC) in which measurement software is installed. The computer 30 and cell placement device 1 are connected through an I/O board for measurement. The I/O board includes an A/D converter 31 and a D/A converter 32. The A/D converter 31 is usually for measuring and converting the resulting potentials; the D/A converter 32 is for stimulus signals to the sample. For example, the A/D converter 31 may have 16 bits, 64 channels, and the D/A converter 32 has 16 bits, 8 channels.

[0023] The measurement software installed in the computer 30 may include software for setting conditions for giving a stimulus signal, forming the stimulus signal, and for recording the obtained detection signal. By using such measurement software, the computer 30 may comprise means for giving a stimulus signal to the cells and means for processing the signal detected from the cells. The computer 30 may also control the optical observation device (SIT camera and image memory device) and the cell culture system.

[0024] An outline of the functionality of the desirable measurement software is described below screen-by-screen.

[0025] On a parameter setting screen, complicated stimulus conditions may be set by drawing a stimulus waveform on the screen by using a keyboard or a mouse. If a setting of recording condition is 64 input channels and a sampling rate of 10 kHz, the computer can handle consecutive recording for several hours. Moreover, electrodes to apply a stimulus signal and electrodes to pick up the detection signal from the cells can be designated by pointing out the microscope images displayed on the screen by the mouse or pen. The temperature, pH, and other conditions of the cell culture system 40 are desirably set from the keyboard.

[0026] On a recording screen, the spontaneous activity potential or induced potential detected from the cells may be displayed in real time. In addition, the recorded spontaneous activity, potential or induced potential can be displayed by overlaying on the microscope image of the cell. When measuring the induced potential, the entire recorded waveform is displayed. When measuring the spontaneous activity potential, by the spike detection function using window discriminator or waveform discriminator, the recorded waveform is displayed only when generation of spontaneous activity is detected. Together with the display of recorded waveform, measurement parameters (e.g., stimulus condition, recording conditions, temperature, pH, etc.) may also be displayed in real time. An alarm function is also provided for warning when the temperature or pH goes out of the allowable range.

[0027] Concerning data analysis or processing, Fourier Function Transform (FFT) analysis, coherence analysis, and correlation analysis are also desirable. Useable

functions may include single spike separation function using waveform discrimination, temporal profile display function, topography display function, and current source density analysis function. These analysis results may be displayed by overlaying on the microscope images stored in the image memory device.

[0028] When a stimulus signal is issued from the computer 30, this stimulus signal is sent to the cell placement device through the D/A converter 32 and an isolator 33. The cell placement device 1 includes a cell potential measuring electrode which may be formed, as described later, of 64 microelectrodes on a glass substrate in a matrix form and having an enclosing wall for maintaining the sample (e.g., segments of cells or tissues) in contact with the microelectrodes and their culture fluid. The stimulus signal sent to the cell placement device 1 is applied to arbitrary electrodes out of the 64 microelectrodes and then to the sample or samples.

[0029] The induced, evoked, or spontaneous potential occurring between each microelectrode and reference potential (which is at the potential of the culture fluid) is passed through a 64 channel high sensitivity amplifier 34 and the A/D converter 31 into the computer 30. The amplification factor of the amplifier 34 may be, e.g., about 80-100 dB, for example, in a frequency band of about 0.1 to 10 kHz, or to 20Hz. However, when measuring the potential induced by a stimulus signal, by using a low-cut filter, the frequency band is 100Hz to 10kHz. Spontaneous potentials are usually in the range of 100Hz to 20Hz.

[0030] The cell culture system 40 usually includes a temperature controller 41, a culture fluid circulation device 42, and a feeder 43 for supplying, e.g., a mixed gas of air and carbon dioxide. The cell culture system 40 may instead be made up of a commercial microincubator, a temperature controller, and CO₂ cylinder. The microincubator can be used to control in a temperature range of 0 to 50°C by means of a Peltier element and is applicable to the liquid feed rate of 3.0 ml/min or less and gas flow rate of 1.0 liter/min or less. Or, a microincubator incorporating a temperature controller may be used.

[0031] The structure of the cell placement device 1 (shown in Figure 1) is explained in more detail with regard to the exploded view found in Fig. 2. The preferred cell placement device 1 may be made up of a cell potential measuring electrode (also called an integrated multiple electrode or microelectrode assembly) 2 having a cylindrical wall 6 provided on a transparent glass substrate and having plural microelectrodes in its inside region, holders 3, 4 divided in two sections for fixing the cell potential measuring electrode 2 by sandwiching from above and beneath, and a printed wiring board 5 for fixing the holders.

[0032] Figure 3 shows the details of the glass substrate. The size of the glass substrate for constituting the cell potential measuring electrode (integrated multiple electrode) 2 may be 1.1 mm in thickness and about 50 mm square. In the central part of the glass substrate, 64 microelectrodes 11 are formed in a matrix form of 8 x 8.

The microelectrodes are insulated from each other and from the reference electrodes. A conductive pattern 12 for wiring is connected to each microelectrode 11. The microelectrode 11 may be about 50 microns square and the distance between centers of adjacent electrodes is about 150 microns. The depicted 64 microelectrodes 11 are therefore shown in a matrix form of 8 x 8, one side of the formed rectangular region is about 1.1 mm.

[0033] Although the Description of the Invention contains many specific references to particular sizes and areas, the invention is not so limited; they are only provided for the sake of guidance and are not critical to the invention unless so stated.

[0034] Also, as shown in Fig. 4, reference electrodes 10 are formed at four positions on lines extended from diagonals of the rectangular region in the central part of the glass substrate in which the microelectrodes are disposed. The reference electrodes are insulated from each other and from the microelectrodes. These reference electrodes 10 are also connected to the electric contacts 7 situated on four sides of the glass substrate by the conductive pattern 12 for wiring same as the microelectrodes 11. The reference electrodes 10 are formed in the same process as the microelectrodes 11, as mentioned below, but the size is generally significantly larger than that of the microelectrodes 11 being, e.g., a rectangle of about 200 microns in one side. Therefore, as compared with one of the microelectrodes 11 of about 50 microns square, the rectangular area is larger, preferably about 16 times larger, and, by this portion, the impedance of the reference electrodes 10 is smaller than the impedance of the microelectrodes 11.

[0035] The positions of the reference electrodes 10 are preferably on lines extending from the diagonals of the rectangular region in the central part of the glass substrate in which the microelectrodes 11 are disposed. The reference electrodes 10 in this variation are located about 6 mm from the center of the rectangular region. Said another way, they are placed at four corners of a square of about 8.5 mm in one side.

[0036] Moreover, as shown in Fig. 4, on each of the four sides of the glass substrate may be found 17 electric contacts 7. These electric contacts 7 are attached (one-by-one) to each of the 64 microelectrodes 11 and four reference electrodes 10 through the conductive pattern 12. The pitch of the 17 electric contacts is desirably spaced to the pitch of 1.27 mm of the universal connector. The manufacturing process of this integrated multiple electrode 2 is explained below by referring to the sectional view in Fig. 5. The depiction in Fig. 5, for the ease of explanation, is not to scale.

[0037] On the surface of a glass substrate 13, an ITO (indium tin oxide) film in a thickness of 150 nm is applied, and a conductive pattern 12 is formed by photo resist and etching. A negative photosensitive polyimide film of about 1.4 microns in thickness is applied thereon, and an insulating film 14 is formed. On portions of the microelectrodes 11 (or alternatively reference electrodes 10)

and electric contacts 7, the ITO film is exposed, and nickel plating 15 of 500 nm in thickness and gold plating 16 of 50 nm in thickness are then applied.

[0038] A polystyrene or glass cylindrical member 6 corresponding to a wall of about 22 mm in inside diameter, about 25 mm in outside diameter, and 8 mm in height may then be placed on the central part of the glass substrate by using a Silicone adhesive (see Fig. 2 and Fig. 4). A highly preferred adhesive is an RTV (Room Temperature Vulcanization) silicone rubber, particularly those which use an acid cure system. These produce a low level of toxicity because of the acetic acid produced during the cure step. Two useful varieties include KE42T (Shin-Etsu Silicone) and Silastic Medical Adhesive Silicone Type A (Dow Corning). A cylindrical wall member 6 is shown, but the wall may be oval to allow enhanced access to the sample. The wall member 6 is affixed in the center of the glass substrate, that is, in a state aligned with the central part of the rectangular region in which the 64 microelectrodes are disposed. In the region enclosed by this cylindrical member 6, the cells or tissues are cultivated. This cylindrical member 6 is filled, e.g., with an aqueous solution of 1 wt.% of chloroplatinic acid, 0.01 wt.% of lead acetate and 0.0025 wt.% of hydrochloric acid, and by passing a current of 20 mA/cm² for a minute, platinum blacks 11a (or alternatively, reference electrode platinum black 10a) are precipitated on the surfaces of the microelectrodes 11 and reference electrodes 10.

[0039] The region within the cylindrical member 6 is occasionally referred to as the "measuring region" which includes the area including both the microelectrodes 11 and reference electrodes 10. It is further within the scope of the invention that the reference electrodes be placed on the inner surface of the cylindrical member 6.

[0040] At one corner of the integrated multiple electrode 2, an indexing or arrow mark 17 showing the direction is provided. This arrow mark 17 can be formed in the same manufacturing process as the microelectrodes 11 and reference electrodes 10. However, the surface is coated with gold plating only, and platinum black is not formed. The length and width of the arrow mark 17 are both about 5 mm. Moreover, near one corner of the rectangular region of disposing the microelectrodes 11, a small indexing mark, e.g., a micro-mark 18 similar to the arrow mark is provided. This micro-mark 18 is not visible by the naked eye, but a same pattern as the arrow mark 17 is recognized in a magnified view by an optical observation device of the measuring apparatus, so that the direction, position, axes, etc. may be identified. Like the arrow mark 17, the micro-mark 18 can be also formed in the same manufacturing process as the microelectrodes 11 and reference electrodes 10.

[0041] In Fig. 2, the integrated multiple electrode 2 is sandwiched between holders 3, 4. An electrical connection is made in the same way. The holders 3, 4 are typically polymeric. The step portion is used to hold the edge of the integrated multiple electrode 2 and the rectangular

openings are formed in the central part. The upper holder 3 is provided with a pair of fasteners 8 and 17 pieces x 4 pairs of contact metal areas 9. A top view of the holders 3, 4 sandwiching and fixing the integrated multiple electrode 2 is shown in Fig. 6(A), its side view (section B-B) in Fig. 6(B), and its perspective back view in Fig. 7. As clear from these diagrams, the fastener 8 is supported by and rotates about shaft pins 8a on two confronting sides of the upper holder 3. As shown in Figure 7, grooves 4a are formed in two confronting sides of the back side of the lower holder 4. Protrusions 8b of the fastener 8 are fitted in grooves 4a and the upper and lower holders 3, 4 are fixed firmly in a state of sandwiching the integrated multiple electrode 2.

[0042] A total of 68 contact metal fittings 9 provided on the upper holder 3 to correspond to the electric contacts 7 of the integrated multiple electrode 2 may be formed by processing elastic and conductive metal plates such as a Be/Cu spring alloy, plated with Ni and Au. The metal fittings 9 have a sectional shape as shown in Fig. 8. That is, it consists of a pin 9a, its base part 9b, and a movable contact part 9d extending from the base part 9b through a curved part 9c. In such structure, the movable contact part 9d can be elastically dislocated from the base part 9b. In the upper holder 3, holes for inserting the pin 9a of the contact metal fitting 9, and grooves for fitting the base part 9b are formed in 68 (17 x 4) positions.

[0043] As shown in Fig. 2 and Fig. 6(B), with the contact metal fitting 9 inserted and fixed in the hole and groove, pin 9a projects from the upper holder 3. Contact metal fittings 9 are of two types which differ in the length of the base part 9b. The two sized fittings 9 are alternately disposed, 16 pins 9a projecting from the upper holder 3 are arranged in two zigzag rows. As mentioned later, these pins 9a are connected to the connectors mounted on the printed wiring board 5 for connection with the outside.

[0044] Movable contact part 9d of the contact metal fitting 9 projects from the lower side of the upper holder 3, when in contact metal fitting 9 is inserted and affixed in the hole and groove of the upper holder 3. With the holders 3, 4 fixed on both sides of the integrated multiple electrode 2, the movable contact part 9d of each contact metal fitting 9 contacts with the electric contact 7 of the integrated multiple electrode 2, and a specified contact pressure is given to the contact area by elastic deformation of the curved part 9c. In this way, the electric contacts 7 for connecting to the microelectrodes 11 and reference electrodes 10 of the integrated multiple electrode 2 through the conductive pattern 12 are electrically connected at a lower contact resistance (30 milliohms or less) as compared with that of the contact metal fittings 9.

[0045] As mentioned above, the holders 3, 4 firmly fixing the integrated multiple electrode 2 in a state of electric contact with the integrated multiple electrode 2 are electrically connected and affixed to the printed wiring board 5 as shown in Fig. 2. The electric connection from the microelectrodes 11 and reference electrode 10 of the integrated multiple electrode 2 to the conductive pattern

12, electric contacts 7 and contact metal fittings 9 is further connected to the cell potential measuring apparatus mentioned above through the printed wiring board 5. Handling of the integrated multiple electrode on the measuring apparatus is facilitated by use of the printed wiring board 5.

[0046] Also as shown in Figure 2, printed circuit board 5 may be made up of, e.g., a glass epoxy two-sided substrate. Connectors 5a are provided at the back side of four positions on the circumference of the circular opening formed in the center of printed circuit board 5. Since 16 pins 9a projecting in two zigzag rows from the four positions on the surface of the upper holder 3 are inserted into the individual corresponding connectors 5a, the assembly of the integrated multiple electrode 2 and holders 3, 4 is fixed to the printed wiring board 5 and is connected electrically.

[0047] At both edges 5b of the printed wiring board 5, electric contacts of 2.54 mm pitch for both edge connectors may be found. These electric contacts and central connectors 5a are connected in the conductive pattern 5c. The inside row of the both connectors 5a is wired by the surface pattern, and the outside row by the back side pattern, respectively, and 34 each on both surface and back sides of both edges 5b, that is, a total of 68 electric contacts are formed. To make the mechanical fixing secure, the upper holder 3 may be affixed to the printed wiring board 5 by fastening with screws.

[0048] The reference electrodes 10 of the integrated multiple electrode 2 are described by reference to Fig. 4. The reference electrodes 10 are usually immersed in the culture fluid as the reference potential for measuring the potential occurring in each microelectrode. Therefore, each microelectrode 11 is connected to an input of the amplifier 34 (Fig. 1), and the reference electrodes 10 are connected to the reference voltage terminals of each amplifier. The 64-channel amplifier is divided into four groups of 16 channels each, and each one of the four reference electrodes is commonly connected to the reference voltage terminal of one group for 16 channels.

[0049] First, as is clear from Fig. 4, it is preferred to position the four reference electrodes 10 on extensions of diagonals of the central rectangular region containing the microelectrodes 11. In general, this is a matter of convenience for pattern wiring. Moreover, in order to place the segments of cells or tissues easily so as to cover all of 64 microelectrodes and not to cover the four reference electrodes, the distance between the central rectangular region disposing the microelectrodes 11 and the reference electrodes 10 should be as large as reasonably possible. Moreover, by placing the four reference electrodes 10 at equal distances from the center of the rectangular region, the noise level occurring in each microelectrode is substantially uniform. Although the positions of the reference electrodes are closely specified above, the numerical values are not intended to be absolute, but are only intended to be guidelines.

[0050] The size of the reference electrodes 10 may be

4-64, preferably about 16, times the area of a microelectrode as mentioned above. As a result, the impedance is balanced between the measuring potential input side of the amplifier and the reference potential input side and the noise level is minimized. For instance, by forming the microelectrodes and reference electrodes in the same noted process and by setting the area of the reference electrode 16 times that of the microelectrode, the impedance of 16 microelectrodes and the impedance of one reference electrode responsible are nearly equal.

Example

[0051] This Example shows the difference in noise level between a system including an integrated multiple electrode such as that discussed above and reference electrodes of 50 microns square and 200 microns square. Fig. 9 and Fig. 10 show those comparative noise levels.

[0052] We fabricated integrated multiple electrodes (such as shown in Fig. 4) having, respectively, reference electrodes of 50 microns square and reference electrodes of 200 microns square. The integrated multiple electrodes each had cylindrical members 6. The same culture medium as normally used in tissue culturing was placed inside the cylindrical members 6. To limit the resulting signal to the noise, no cell or tissue sample was placed on the microelectrodes. As shown in Fig. 11, of the 64 microelectrodes, the central seven sites (channels 1 to 5, 7, 8) were measured.

[0053] Fig. 9 shows the noise waveform of the reference electrodes in 50 microns square, and Fig. 10, 200 microns square. In each diagram, the voltage on the axis of ordinates is 0.02 mV/div, and the time on the axis of abscissas is 5.0 ms/div. As clear from comparison between Fig. 9 and Fig. 10, the noise level is clearly smaller when the reference electrodes are 200 microns square (Fig. 10) as compared to reference electrodes with 50 microns square (Fig. 9). Incidentally, as described in relation to the prior art, by using one of the 64 microelectrodes as the reference electrode to be responsible for 16 microelectrodes, the noise level was as large as in Fig. 9.

[0054] As described herein, according to the cell potential measuring electrode and apparatus of the invention, the noise effect is small, and if positioning when setting the segments of cells or tissues to be measured is not very precise, all microelectrodes are effectively utilized, and potentials at multiple points can be measured simultaneously.

Claims

1. A cell potential measuring electrode assembly (2) suitable for measuring electrical potential in a neural sample comprising:

a) a plurality of measurement microelectrodes

- (11) insulated from each other and located on an insulating substrate (13) and forming a measurement microelectrode region,
 b) a plurality of reference electrodes (10) isolated from each other and located on said insulating substrate outside of said measurement microelectrode region, each of said plurality of reference electrodes having an impedance smaller than said each of said measurement microelectrodes (11) when measured in an electrolyte covering said measuring region at 1 kHz, 50 mv.
2. The cell potential measuring electrode assembly (2) of claim 1 wherein the area of each of the plurality of reference electrodes (10) is larger than the area of each of the plurality of measurement microelectrodes (11).
 3. The cell potential measuring electrode assembly (2) of claim 2 wherein the area of each of the plurality of reference electrodes (10) is 4 to 25 times the area of each of plurality of measurement microelectrodes (11).
 4. The cell potential measuring electrode assembly (2) of claim 2 wherein the area of said each of plurality of measurement microelectrodes (11) is 4×10^2 to $4 \times 10^4 \mu\text{m}^2$ and the area of each of the plurality of reference electrodes (10) is 64×10^2 to $64 \times 10^4 \mu\text{m}^2$.
 5. The cell potential measuring electrode assembly (2) of claim 1 wherein each of the plurality of measurement microelectrodes (11) are situated in an array in said measuring region.
 6. The cell potential measuring electrode assembly (2) of claim 5 wherein 64 microelectrodes (11) are disposed in eight rows and eight lines at central pitches of 100 to 450 microns.
 7. The cell potential measuring electrode assembly (2) of claim 1 wherein each of the plurality of measurement microelectrodes (11) and each of the plurality of reference electrodes (10) are connectable to a position outside of the measuring region.
 8. The cell potential measuring electrode assembly (2) of claim 1 wherein the measuring region is surrounded by a wall (6).
 9. The cell potential measuring electrode assembly (2) of claim 8 wherein the wall (6) is circular.
 10. The cell potential measuring electrode assembly (2) of claim 8 wherein the wall (6) is oval.
 11. The cell potential measuring electrode assembly (2) of claim 1, further comprising:
 - a conductive pattern (12) for wiring of said microelectrodes (11) and said reference electrodes (10);
 - an electric contact (7) connected to the end of said conductive pattern;
 - an insulating film (14) covering the surface of said conductive pattern; and
 - a wall (6) enclosing an area including said measurement microelectrode region and said reference electrodes for use in measurement of electrophysiological activities while cultivating cells or tissues in a region enclosed by said wall.
 12. The cell potential measuring electrode assembly (2) of claim 11, wherein said plural reference electrodes (10) are disposed at nearly equal distance from the region of disposition of said plural microelectrodes (11) and at intervals of nearly equal angle.
 13. The cell potential measuring electrode assembly (2) of claim 12, wherein said plural microelectrodes (11) are disposed in a matrix in a rectangular region, and four of said reference electrodes (10) are provided on an extension of diagonals of said rectangular region.
 14. The cell potential measuring electrode assembly (2) of claim 13, wherein said microelectrodes (11) are 0.8 to 3.3 mm in one side of a rectangular region in matrix arrangement, and said four reference electrodes (10) are disposed at four corners of a rectangular form of 5 to 15 mm in one side.
 15. The cell potential measuring electrode assembly (2) of claim 14, wherein 64 microelectrodes (11) are disposed in eight rows and eight lines at central pitches of 100 to 450 microns.
 16. The cell potential measuring electrode assembly (2) of claim 11, wherein the area of said reference electrodes (10) is 4 to 25 times the area of said microelectrodes (11).
 17. The cell potential measuring electrode assembly (2) of claim 16, wherein the area of said reference electrodes (10) is 16 times the area of said microelectrodes (11).
 18. The cell potential measuring electrode assembly (2) of claim 11, wherein the area of said microelectrodes (11) is 4×10^2 to $4 \times 10^4 \mu\text{m}^2$ and the area of said reference electrodes (10) is 64×10^2 to $64 \times 10^4 \mu\text{m}^2$.
 19. The cell potential measuring electrode assembly (2) of claim 11, wherein said microelectrodes (11) and

said reference electrodes (10) are formed of a same material.

20. The cell potential measuring electrode assembly (2) of claim 19, wherein said microelectrodes (11) and said reference electrodes (10) are formed by layering nickel plating, gold plating, and platinum black on an indium-tin oxide film.

21. The cell potential measuring electrode assembly (2) of claim 11, wherein said insulating substrate (13) is nearly square, and plural electric contacts (7) connected to the end of said conductive pattern (12) are distributed and disposed in four sides of said insulating substrate.

22. The cell potential measuring electrode assembly (2) of claim 11, wherein indexing micro-marks (17) for visually recognizing direction when magnified are provided near the regions of disposition of said microelectrodes (11).

23. A cell potential measuring apparatus comprising:

a cell placement device (1) having a cell potential measuring electrode assembly (2) as defined in any one of claims 11 to 22, and a contact metal (9) for contacting with its electric contact (7), and including an electrode holder (3, 4) for fixing said insulating substrate (13) by sandwiching from above and beneath, a signal processor (30) connected electrically to said cell placement device (1) for processing voltage signals generated between each microelectrode (11) and reference electrode (10) of said cell potential measuring electrode (2) by the activity of cells or tissues cultivated in a region enclosed by a wall (6), and an optical device (21) for magnifying and observing optically the cells or tissues cultivated in the region enclosed by said wall (6).

24. A cell potential measuring apparatus of claim 23, further comprising an image memory device (22) for storing the magnified image obtained by aid optical device (21).

Patentansprüche

1. Elektrodenanordnung zur Messung von Zellpotentialen (2), die zur Messung eines elektrischen Potentials in einer neuronalen Probe geeignet ist, mit:

a) einer Vielzahl von Meßmikroelektroden (11), die gegeneinander isoliert und auf einem isolierenden Substrat (13) angeordnet sind und einen Meßmikroelektrodenbereich bilden,

b) einer Vielzahl von Referenzelektroden (10), die gegeneinander isoliert und auf dem isolierenden Substrat außerhalb des Meßmikroelektrodenbereichs angeordnet sind, wobei jede aus der Vielzahl von Referenzelektroden eine Impedanz hat, die kleiner ist als jede der Meßmikroelektroden (11), wenn in einem Elektrolyt, der den Messungsbereich umfaßt, mit 1 kHz, 50 mV gemessen wird.

2. Elektrodenanordnung zur Messung von Zellpotentialen (2) nach Anspruch 1, wobei die Fläche jeder aus der Vielzahl von Referenzelektroden (10) größer ist als die Fläche jeder aus der Vielzahl von Meßmikroelektroden (11).

3. Elektrodenanordnung zur Messung von Zellpotentialen (2) nach Anspruch 2, wobei die Fläche jeder aus der Vielzahl von Referenzelektroden (10) das 4- bis 25fache der Fläche jeder aus der Vielzahl von Meßmikroelektroden (11) ist.

4. Elektrodenanordnung zur Messung von Zellpotentialen (2) nach Anspruch 2, wobei die Fläche jeder aus der Vielzahl von Meßmikroelektroden (11) 4×10^2 bis $4 \times 10^4 \mu\text{m}^2$ ist und die Fläche jeder aus der Vielzahl der Referenzelektroden (10) 64×10^2 bis $64 \times 10^4 \mu\text{m}^2$ ist.

5. Elektrodenanordnung zur Messung von Zellpotentialen (2) nach Anspruch 1, wobei jede aus der Vielzahl von Meßmikroelektroden (11) in einer Matrix in dem Messungsbereich angeordnet ist.

6. Elektrodenanordnung zur Messung von Zellpotentialen (2) nach Anspruch 5, wobei 64 Mikroelektroden (11) in acht Reihen und acht Zeilen mit mittigen Rastermaßen von 100 bis 450 μm angeordnet sind.

7. Elektrodenanordnung zur Messung von Zellpotentialen (2) nach Anspruch 1, wobei jede aus der Vielzahl von Meßmikroelektroden (11) und jede aus der Vielzahl von Referenzelektroden (10) mit einer Position außerhalb des Messungsbereichs verbindbar sind.

8. Elektrodenanordnung zur Messung von Zellpotentialen (2) nach Anspruch 1, wobei der Messungsbereich von einer Wand (6) umgeben ist.

9. Elektrodenanordnung zur Messung von Zellpotentialen (2) nach Anspruch 8, wobei die Wand (6) kreisförmig ist.

10. Elektrodenanordnung zur Messung von Zellpotentialen (2) nach Anspruch 8, wobei die Wand (6) oval ist.

11. Elektrodenanordnung zur Messung von Zellpotentialen (2) nach Anspruch 1, ferner mit:

einer Leiterstruktur (12) zum Verdrahten der Mikroelektroden (11) und der Referenzelektroden (10);
 einem elektrischen Kontakt (7), der mit dem Ende der Leiterstruktur verbunden ist;
 einem isolierenden Film (14), der die Oberfläche der Leiterstruktur überdeckt; und
 einer Wand (6), die eine Fläche mit dem Meßmikroelektrodenbereich und den Referenzelektroden einschließt, zur Verwendung beim Messen von elektrophysiologischen Aktivitäten, während Zellen oder Gewebe in einem von der Wand eingeschlossenen Bereich kultiviert werden.

12. Elektrodenanordnung zur Messung von Zellpotentialen (2) nach Anspruch 11, wobei die mehreren Referenzelektroden (10) in nahezu gleichem Abstand vom Anordnungsbereich der mehreren Mikroelektroden (11) und in Intervallen von nahezu gleichem Winkel angeordnet sind.

13. Elektrodenanordnung zur Messung von Zellpotentialen (2) nach Anspruch 12, wobei die mehreren Mikroelektroden (11) in einer Matrix in einem rechteckigen Bereich angeordnet sind und vier der Referenzelektroden (10) auf einer Verlängerung von Diagonalen des rechteckigen Bereichs angeordnet sind.

14. Elektrodenanordnung zur Messung von Zellpotentialen (2) nach Anspruch 13, wobei die Mikroelektroden (11) 0,8 bis 3,3 mm an einer Seite eines rechteckigen Bereichs in Matrixanordnung sind und die vier Referenzelektroden (10) an vier Ecken einer rechteckigen Form von 5 bis 15 mm an einer Seite angeordnet sind.

15. Elektrodenanordnung zur Messung von Zellpotentialen (2) nach Anspruch 14, wobei 64 Mikroelektroden (11) in acht Reihen und acht Linien mit mittigen Rastermaßen von 100 bis 450 μm angeordnet sind.

16. Elektrodenanordnung zur Messung von Zellpotentialen (2) nach Anspruch 11, wobei die Fläche der Referenzelektroden (10) das 4- bis 25fache der Fläche der Mikroelektroden (11) ist.

17. Elektrodenanordnung zur Messung von Zellpotentialen (2) nach Anspruch 16, wobei die Fläche der Referenzelektroden (10) das 16fache der Fläche der Mikroelektroden (11) ist.

18. Elektrodenanordnung zur Messung von Zellpotentialen (2) nach Anspruch 11, wobei die Fläche der

Mikroelektroden (11) 4×10^2 bis $4 \times 10^4 \mu\text{m}^2$ ist und die Fläche der Referenzelektroden (10) 64×10^2 bis $64 \times 10^4 \mu\text{m}^2$ ist.

19. Elektrodenanordnung zur Messung von Zellpotentialen (2) nach Anspruch 11, wobei die Mikroelektroden (11) und die Referenzelektroden (10) aus dem gleichen Material bestehen.

20. Elektrodenanordnung zur Messung von Zellpotentialen (2) nach Anspruch 19, wobei die Mikroelektroden (11) und die Referenzelektroden (10) durch Aufbringen von Nickelplattierung, Goldplattierung und Platinschwarz auf einem Indium-Zinnoxidfilm ausgebildet sind.

21. Elektrodenanordnung zur Messung von Zellpotentialen (2) nach Anspruch 11, wobei das isolierende Substrat (13) nahezu quadratisch ist und mehrere elektrische Kontakte (7), die mit dem Ende der Leiterstruktur (12) verbunden sind, an vier Seiten des isolierenden Substrats verteilt und angeordnet sind.

22. Elektrodenanordnung zur Messung von Zellpotentialen (2) nach Anspruch 11, wobei Hinweismarkierungen (17) zur optischen Erkennung der Richtung bei Vergrößerung nahe den Anordnungsbereichen der Mikroelektroden (11) vorgesehen sind.

23. Eine Vorrichtung zur Messung von Zellpotentialen mit:

einer Zellplatzierungsvorrichtung (1) mit einer Elektrodenanordnung zur Messung von Zellpotentialen (2) nach einem der Ansprüche 11 bis 22 und einem Kontaktmetall (9) zur Kontaktherstellung mit ihrem elektrischen Kontakt (7) und mit einem Elektrodenhalter (3, 4) zum Fixieren des isolierenden Substrats (13) durch sandwichartiges Anordnen von oben und unten, einem Signalprozessor (30), der mit der Zellplatzierungsvorrichtung (1) elektrisch verbunden ist, zur Verarbeitung von Spannungssignalen, die zwischen jeder Mikroelektrode (11) und Referenzelektrode (10) der Zellpotentialmeßelektrode (2) durch die Aktivität von Zellen oder Geweben erzeugt werden, die in einem von einer Wand (6) eingeschlossenen Bereich kultiviert werden, und einer optischen Vorrichtung (21) zum optischen Vergrößern und Beobachten der Zellen oder Gewebe, die in dem von der Wand (6) eingeschlossenen Bereich kultiviert werden.

24. Vorrichtung zur Messung von Zellpotentialen nach Anspruch 23, ferner mit einer Bildspeichervorrichtung (22) zum Speichern des durch die optische Vor-

richtung (21) gewonnenen, vergrößerten Bildes.

Revendications

1. Ensemble d'électrode de mesure de potentiel de cellule (2) adéquat pour la mesure le potentiel électrique dans un échantillon neural comprenant :

a) une pluralité de microélectrodes de mesure (11) isolées les unes des autres et placées sur un substrat d'isolation (13) et formant une région de microélectrode de mesure,
b) une pluralité d'électrodes de référence (10) isolées les unes des autres et placées sur ledit substrat d'isolation à l'extérieur de ladite région de microélectrode de mesure, chacune de ladite pluralité d'électrodes de référence ayant une impédance inférieure à ladite chacune desdites microélectrodes de mesure (11) lorsqu'on la mesure dans un électrolyte couvrant ladite région de mesure à 1 kHz, 50 mv.

2. Ensemble d'électrode de mesure de potentiel de cellule (2) selon la revendication 1 dans lequel l'aire de chacune de la pluralité d'électrodes de référence (10) est supérieure à l'aire de chacune de la pluralité des microélectrodes de mesure (11).

3. Ensemble d'électrode de mesure de potentiel de cellule (2) selon la revendication 2 dans lequel l'aire de chacune de la pluralité d'électrodes de référence (10) est 4 à 25 fois l'aire de chacune de la pluralité des microélectrodes de mesure (11).

4. Ensemble d'électrode de mesure de potentiel de cellule (2) selon la revendication 2 dans lequel l'aire de ladite chacune de la pluralité des électrodes de mesure (11) est de 4×10^2 à $4 \times 10^4 \mu\text{m}^2$ et l'aire de chacune de la pluralité des électrodes de référence (10) est de 64×10^2 à $64 \times 10^4 \mu\text{m}^2$.

5. Ensemble d'électrode de mesure de potentiel de cellule (2) selon la revendication 1 dans lequel chacune de la pluralité des microélectrodes de mesure (11) est située dans une matrice dans ladite région de mesure.

6. Ensemble d'électrode de mesure de potentiel de cellule (2) selon la revendication 5 dans lequel 64 microélectrodes (11) sont disposées dans huit rangées et huit lignes à des pas centraux de 100 à 450 microns.

7. Ensemble d'électrode de mesure de potentiel de cellule (2) selon la revendication 1 dans lequel chacune de la pluralité des microélectrodes de mesure (11) et chacune de la pluralité des électrodes de référen-

ce (10) sont connectables à une position à l'extérieur de la région de mesure.

8. Ensemble d'électrode de mesure de potentiel de cellule (2) selon la revendication 1 dans lequel la région de mesure est entourée par une paroi (6).

9. Ensemble d'électrode de mesure de potentiel de cellule (2) selon la revendication 8 dans lequel la paroi (6) est circulaire.

10. Ensemble d'électrode de mesure de potentiel de cellule (2) selon la revendication 8 dans lequel la paroi (6) est ovale.

11. Ensemble d'électrode de mesure de potentiel de cellule (2) selon la revendication 1, comprenant de plus :

une impression conductrice (12) pour le câblage desdites microélectrodes (11) et desdites électrodes de référence (10) ;

un contact électrique (7) connecté à l'extrémité de ladite impression conductrice ;

un film d'isolation (14) couvrant la surface de ladite impression conductrice; et

une paroi (6) enfermant une aire comprenant ladite région de microélectrode de mesure et lesdites électrodes de référence pour une utilisation dans la mesure des activités électrophysiologiques pendant la culture de cellules ou de tissus dans une région enfermée au moyen de ladite paroi.

12. Ensemble d'électrode de mesure de potentiel de cellule (2) selon la revendication 11, dans lequel ladite pluralité d'électrodes de référence (10) est disposée à presque une distance égale de la région de disposition desdites microélectrodes plurales (11) et à des intervalles de presque un angle égal.

13. Ensemble d'électrode de mesure de potentiel de cellule (2) selon la revendication 12, dans lequel lesdites microélectrodes plurales (11) sont disposées dans une matrice dans une région rectangulaire, et quatre desdites électrodes de référence (10) sont fournies sur une extension de diagonales de ladite région rectangulaire.

14. Ensemble d'électrode de mesure de potentiel de cellule (2) selon la revendication 13, dans lequel lesdites microélectrodes (11) sont de 0,8 à 3,3 mm dans un côté d'une région rectangulaire dans un arrangement de matrice, et lesdites quatre électrodes de référence (10) sont disposées à quatre coins d'une forme rectangulaire de 5 à 15 mm dans un côté.

15. Ensemble d'électrode de mesure de potentiel de cel-

- lule (2) selon la revendication 14, dans lequel 64 microélectrodes (11) sont disposées dans huit rangées et huit lignes à des pas centraux de 100 à 450 microns.
- 5
16. Ensemble d'électrode de mesure de potentiel de cellule (2) selon la revendication 11, dans lequel l'aire desdites électrodes de référence (10) est de 4 à 25 fois l'aire desdites microélectrodes (11).
- 10
17. Ensemble d'électrode de mesure de potentiel de cellule (2) selon la revendication 16, dans lequel l'aire desdites électrodes de référence (10) est 16 fois l'aire desdites microélectrodes (11).
- 15
18. Ensemble d'électrode de mesure de potentiel de cellule (2) selon la revendication 11, dans lequel l'aire desdites microélectrodes (11) est de 4×10^2 à $4 \times 10^4 \mu\text{m}^2$ et l'aire desdites électrodes de référence (10) est de 64×10^2 à $64 \times 10^4 \mu\text{m}^2$.
- 20
19. Ensemble d'électrode de mesure de potentiel de cellule (2) selon la revendication 11, dans lequel lesdites microélectrodes (11) et lesdites électrodes de référence (10) sont formées d'un même matériau.
- 25
20. Ensemble d'électrode de mesure de potentiel de cellule (2) selon la revendication 19, dans lequel lesdites microélectrodes (11) et lesdites électrodes de référence (10) sont formées au moyen d'un placage de couche de nickel, de placage d'or, et de platine noir sur un film d'oxyde d'étain indium.
- 30
21. Ensemble d'électrode de mesure de potentiel de cellule (2) selon la revendication 11, dans lequel ledit substrat d'isolation (13) est presque carré, et les contacts électriques pluraux (7) connectés à l'extrémité de ladite impression conductrice (12) sont distribués et disposés dans quatre côtés dudit substrat d'isolation.
- 35
- 40
22. Ensemble d'électrode de mesure de potentiel de cellule (2) selon la revendication 11, dans lequel l'indexation de micro marques (17) pour reconnaître visuellement la direction lorsqu'un agrandissement est fourni près des régions de disposition desdites microélectrodes (11).
- 45
23. Appareil de mesure de potentiel de cellule comprenant :
- 50
- un dispositif de placement de cellule (11) ayant un ensemble d'électrode de mesure de potentiel de cellule (2) tel que défini dans l'une quelconque des revendications 11 à 22, et un métal de contact (9) pour être en contact avec son contact électrique (7), et comprenant un support d'électrode (3, 4) pour la fixation dudit substrat d'iso-
- 55
- lation (13) en couche intermédiaire depuis le dessus et le dessous, un processeur de signal (30) connecté électriquement audit dispositif de placement de cellule (1) pour traiter les signaux de tension générés entre chaque microélectrode (11) et l'électrode de référence (10) de ladite électrode de mesure de potentiel de cellule (2) au moyen de l'activité des cellules ou des tissus cultivés dans une région enfermée au moyen d'une paroi (6), et un dispositif optique (21) pour agrandir et observer de façon optique les cellules ou les tissus cultivés dans la région enfermée au moyen de ladite paroi (6).
24. Appareil mesurant un potentiel de cellule selon la revendication 23, comprenant de plus un dispositif de mémoire d'image (22) pour stocker l'image agrandie obtenue au moyen du dispositif optique d'aide (21).

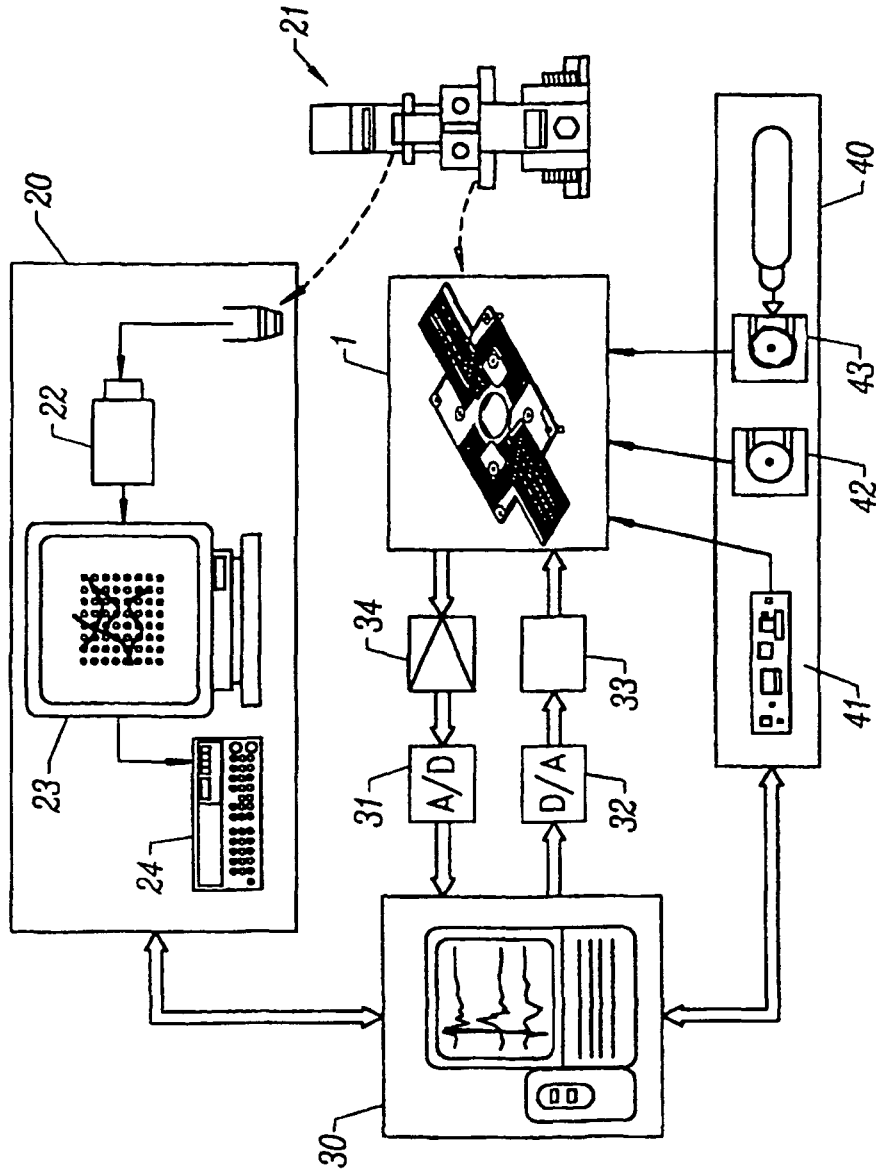

FIG. 1

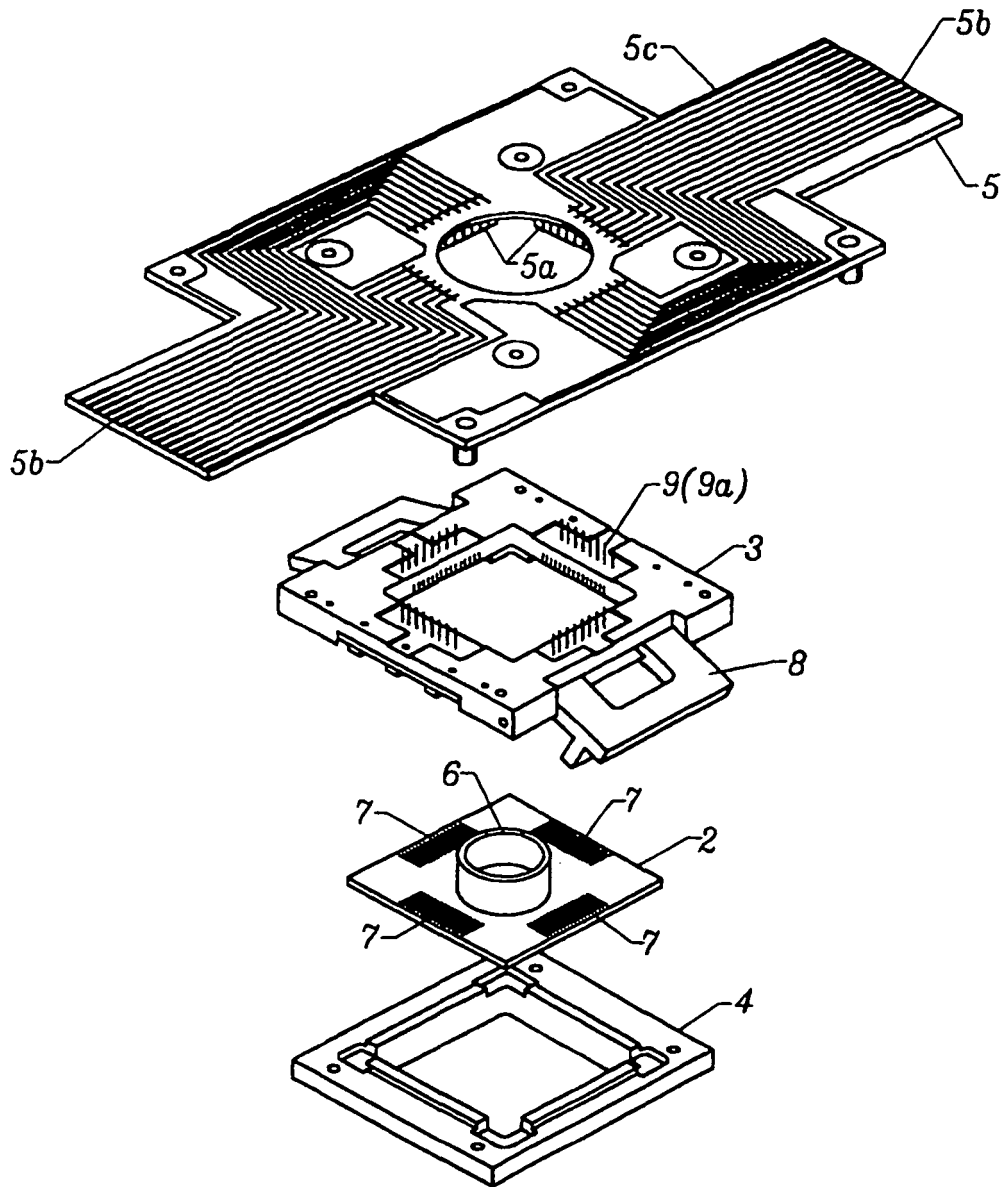

FIG. 2

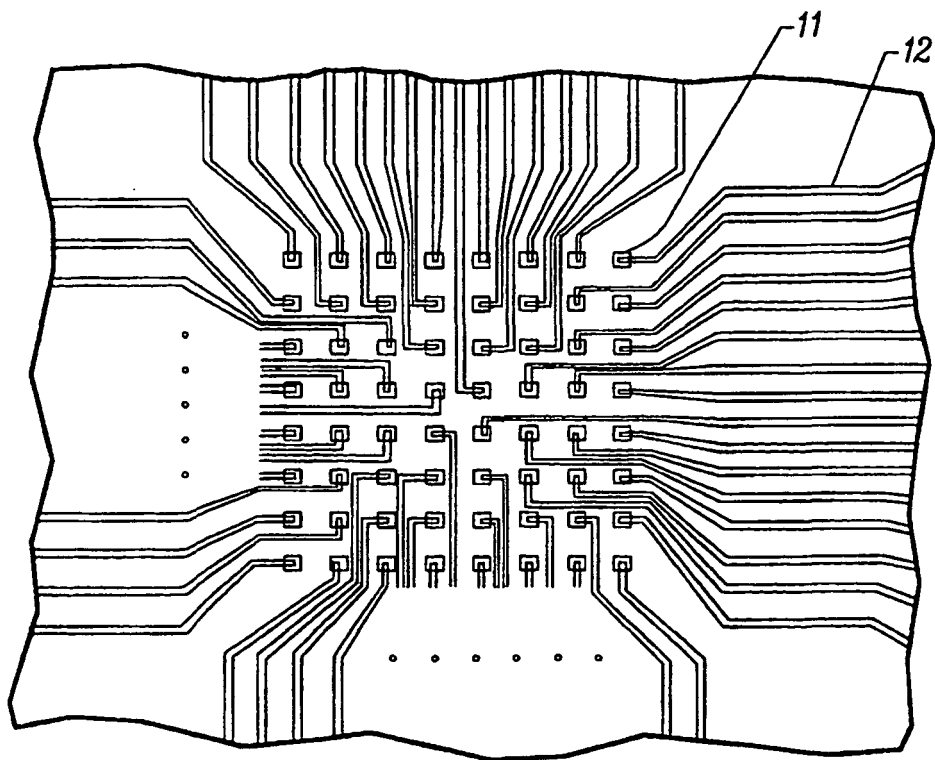

FIG. 3

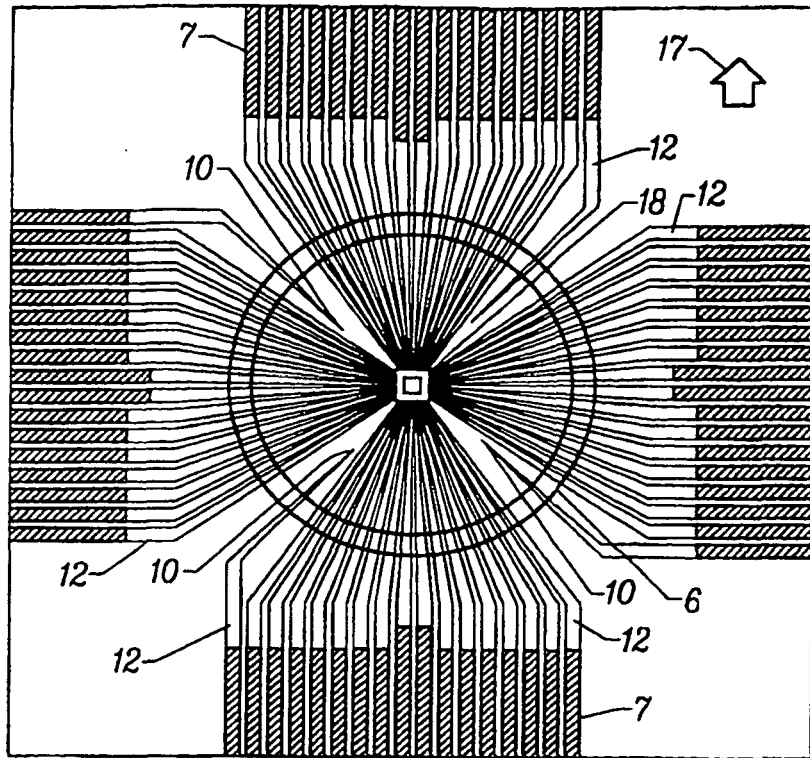

FIG. 4

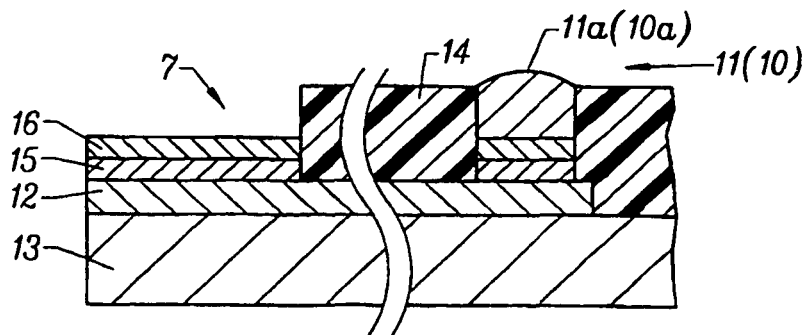

FIG. 5

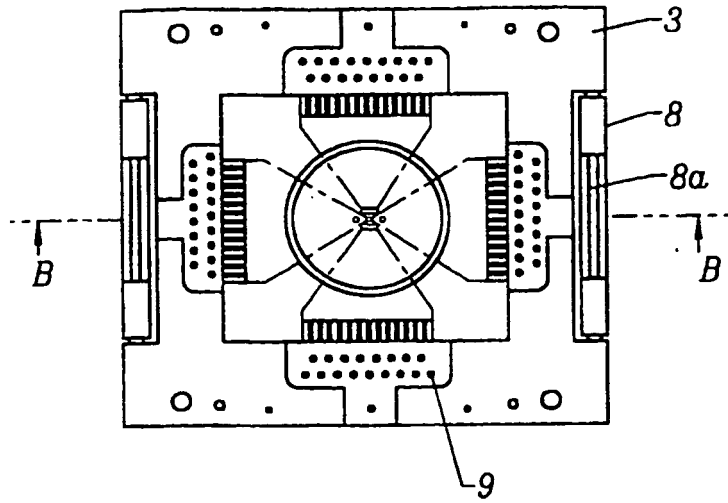

FIG. 6A

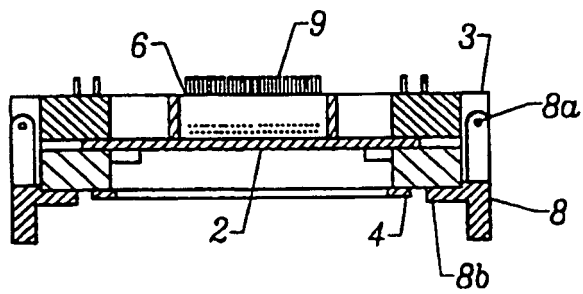
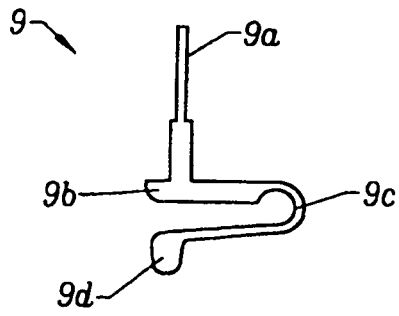
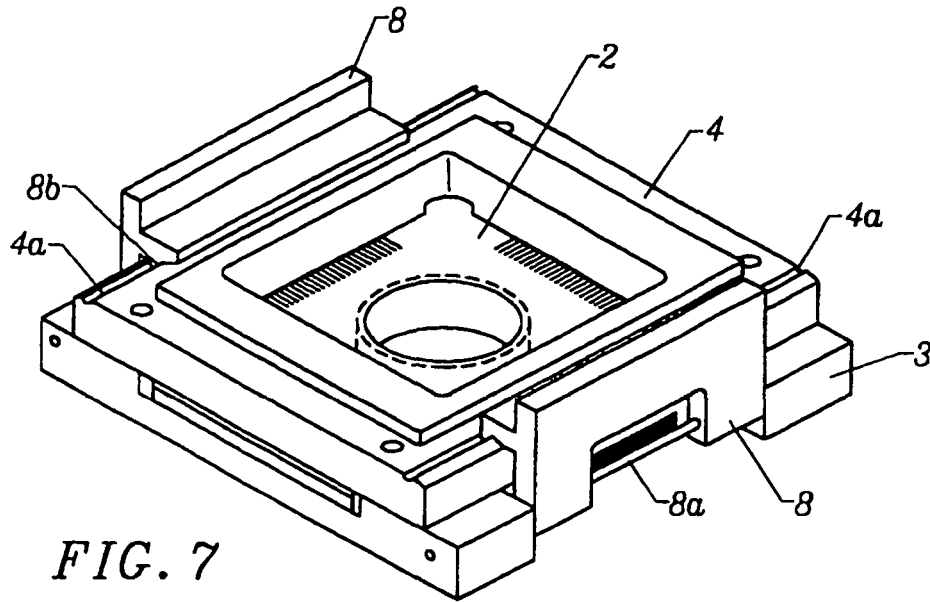

FIG. 6B



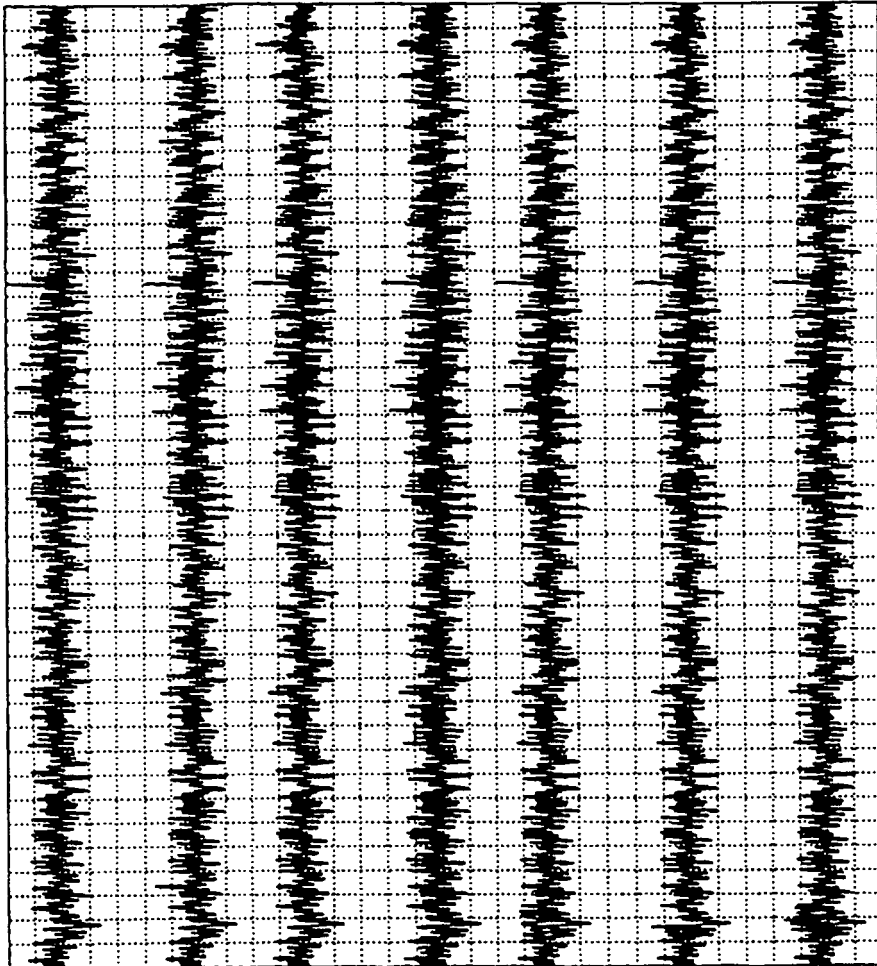

FIG. 9

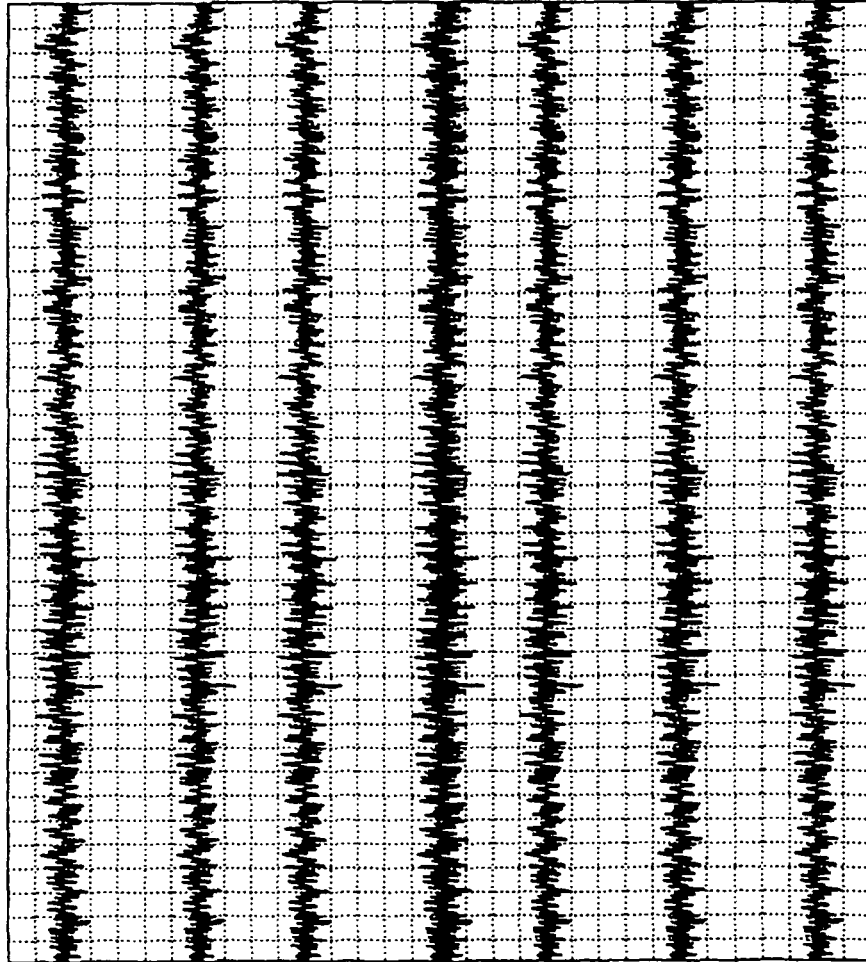

FIG. 10

E							
			1	5			
			2	7			
			3	8			
			4				

FIG. 11

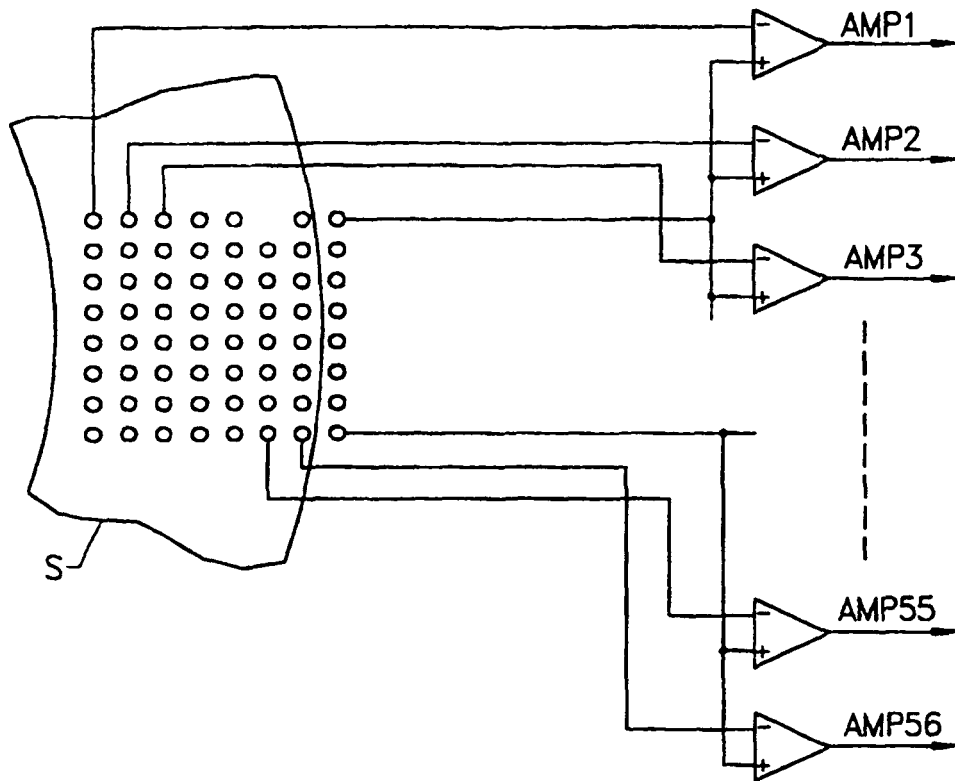

FIG. 12